

## LAVIOSEAL HI-FLEX (HF) Swelling Bentonite Waterstop for Joints Sealing

### Bentonite

Bentonite is a clay mineral of the smectite group and is composed mainly of montmorillonite. The smectites are a group of minerals that swell as they absorb water or organic molecules within the structural layers; they also have considerable cationic exchange properties.



The clay mineral they are composed of in the crystalline state is derived from the devitrification, and consequent chemical change, of glass of magmatic origin, usually tufa or volcanic ash (definition by Ross and Shannon, 1926).

The nature and volcanic origins of bentonite deposits give rise to varieties of the mineral that are often extremely heterogeneous. The bentonites that are thus formed that can be described as sodium, calcium and acid bentonites.

The crystallographic basis of the montmorillonite (bentonite) is typical of phyllosilicates: sheets of AlX octahedrons (X=oxygen or oxydriil) between two sheets of SiO<sub>4</sub> tetrahedrons.

In the octahedron layer the Aluminum may be replaced by magnesium, thus giving rise to an excess negative charge: the negative charge in excess is

compensated for by various mono and bivalent cations (Ca<sup>++</sup>, Mg<sup>++</sup>, Na<sup>+</sup>...).

This elementary particle is a lamella: the various lamellas are held together in "packets" by Van der Waals force, but they can be "delamellised" and dispersed in water in submicronic particles until a specific superficial area of 800 m<sup>2</sup>/g is developed.

A reliable barrier system is realized with the use of sodium bentonite, which has a high grade for swelling (higher than 24 ml/2g) and water absorption (higher than 600%), and gives rise to a gelling with excellent waterproofing properties.

### Product Description

Lavioseal HF is a swelling sealing strip used in below grade construction for the sealing of the vertical and horizontal joints.

It is a specially formulated joint seal made up of a natural sodium bentonite base with butyl rubber to form a highly concentrated and compact material which can be produced in many forms, from a strip several metres long with a rectangular cross section (20x25 mm).

One of the most important characteristic of Lavioseal HF waterstop is the high swelling capability when the waterstop becomes in contact with water: this process allows the formation of a waterproofing barrier for the concrete joints.

Because of the high density of the sealing strip, it will hold its profile even

after free swelling, and will not disintegrate on free swell as some other bentonite sealants do when in contact with water for a long time.

Lavioseal HF is manufactured in coils for ease of handling. The installation is very simple and fast and it can be done just by fixing it with nails to the previous poured concrete; it should be positioned approximately 7-8 cm from the exterior concrete border surface.

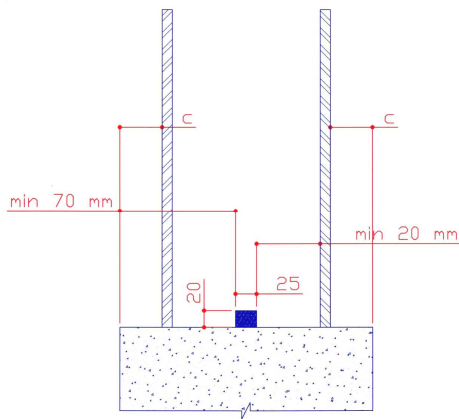

Usually the waterstop is positioned on the inside of the outermost line of reinforcing bar. This gives the required thickness of concrete to the outer surface to confine the sealing strip, avoiding any crack due to the waterstop swelling. The Lavioseal HF should be held firmly in position by nails (spacing 20 - 25 cm) to ensure that the sealing strip remains in position while the concrete is poured.

## Fields of Application

Lavioseal HF is a swelling waterstop used for sealing cold joints in concrete structures, both in vertical and horizontal application, when the structures is subjected to water during its working life. It can be used both in hydrostatic and non-hydrostatic conditions.



## Limits

Lavioseal HF is not designed or intended for waterproofing the expansion joints of the structure. The complete functionality of the waterstop is reached by a uniform confinement of the sealing strip by the concrete.

The Lavioseal HF is intended for use in contact with waters characterized by a "normal content" of chemical agents. In case of application in contact with high salinity waters or high content of chemical aggressive agents, please contact our R&D laboratory.

*Information given in this bulletin is based on the state of our knowledge at the date of publication and are believed to be accurate, but do not constitute any engagement or warranty from our part. Buyers and users should make their own assessments under their own conditions and for their own requirements. Information may be changed without any notice. For mandatory characteristics and performance please refer to our Sale Specifications.*