

## LAVIOSEAL HI-FLEX (HF) INSTALLATION GUIDELINES

### Preparation of the Installation area

The following are the preliminary operations required to ensure that the LAVIOSEAL HF joint functions perfectly:

- the surfaces which are to be treated with LAVIOSEAL HF must be clean and any particles of extraneous material that could be deposited must be removed;
- even small amounts of stagnant water that have collected must be removed from the joint sealing area;
- all macroscopic unevenness in the concrete must be removed and care must be taken to level the surfaces in such a way as to ensure the best possible contact between the strip and the surfaces to be sealed (a necessary condition if optimum waterproofing of the joint is to be achieved).

### Waterstop installation

During installation the following steps are foreseen:

- prepare a strip of LAVIOSEAL HF before applying it to the surface of the previously prepared cement;
- position the strip roughly in the centre of the section to be sealed, which must not be wider than 45 cm. For wider structures, a double strip of bentonite can be positioned at a distance of approximately 5 cm;
- for vertical installations, start from the bottom in order to prevent any risk of distortion or stretching;
- the water-stop must be covered with a concrete cast of 8 cm minimum in all directions;

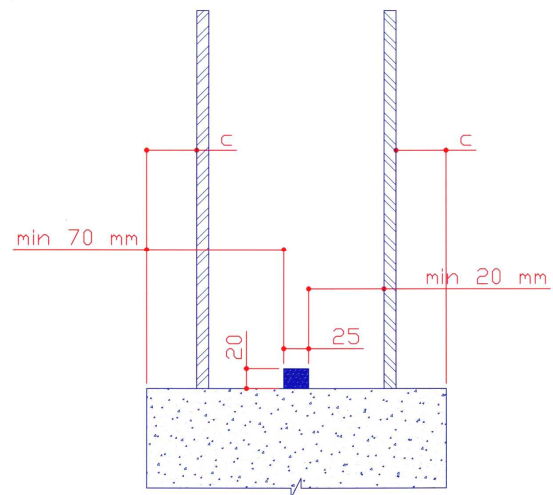

- the bentonite strip must not be used to support reinforcements;
- the reinforcements must be positioned at a minimum distance of  $2\Phi$  (as  $\Phi$  is the diameter of the iron reinforcements closest to the joint) in such a way that the free re-expansion of the bentonite is not hindered;
- for horizontal applications, a minimum bending radius of 12-15 cm must be maintained at the bends;
- at  $90^\circ$  bends in horizontal applications, it is advisable to cut the strip and start again with a vertical joint;
- it must be remembered that the water-stop must adhere perfectly to the concrete without leaving any breaks through which micro-penetrations of the concrete cast could adversely affect the final sealing of the joint.

## Waterstop fixing

Rivet the strip to the surface as follows:

- for horizontal applications there must be 25-30 cm between the centers of two consecutive rivets;
  - at bends in horizontal applications, the rivets must be positioned at the beginning and at the end of a short bending stretch (max. 25 cm). For long bending stretches it is advisable to increase the number of rivets in accordance with requirements;
  - for vertical applications the number of rivets must be increased to a maximum distance of 20 cm between the centers of two consecutive rivets;
  - at each end of the strip, a starting rivet must always be positioned at a distance of 2-3 cm from the free end;
- it is advisable to use wide-head rivets with a washer inserted between the rivet head and the surface of the strip, taking care that the washer does not penetrate the strip during the securing operations;
  - when securing has been completed, a concrete cast must be laid no later than 24-36 hours afterwards. In adverse weather conditions and in hot climates, the time between securing the water-stop and casting the concrete must be reduced to a minimum;
  - laying temperatures: air temperature from  $-5^{\circ}\text{C}$  to  $+55^{\circ}\text{C}$ .

---

*Information given in this bulletin is based on the state of our knowledge at the date of publication and are believed to be accurate, but do not constitute any engagement or warranty from our part. Buyers and users should make their own assessments under their own conditions and for their own requirements. Information may be changed without any notice. For mandatory characteristics and performance please refer to our Sale Specifications.*